

# VENETIAN BLINDS

## SPECIFICATION SHEET



Call the Blind & Awning experts now to book your  
free in-home consultation, measure and quote

**0800 10 27 10**  
**WWW.WEATHERMASTER.CO.NZ**

**Weathermaster**<sup>®</sup>  
THE BLIND & AWNING EXPERTS

Copyright 2010 This document may not be reproduced without  
authorisation from New Zealand Window Shades Limited

# ALUMINIUM VENETIAN BLINDS

## PRODUCT OVERVIEW



Weathermaster Aluminium Venetian Blinds have a well earned reputation for technical reliability and durable construction. They are highly functional and decorative. We use the best materials, aluminium alloys and paint systems in conjunction with automated assembly methods to manufacture a product that represents true value for money.

### Venetian Blinds Models

- 25mm Slimline
- 50mm Classic
- 25mm Twi-Nighter®
- 25mm Between-Glass

### Colour Range

The Weathermaster colour range is the most extensive in New Zealand.

25mm width and TWI-NIGHTER® - 60+ colours plus, including 6 colours in perforated slat.  
50mm - 9 colours including 1 perforated slat

### Applications

- Any internal installation where heat, light and / or privacy control are required
- In between double glazing panes
- Partition walls
- Rectangular and special shaped windows
- Automated operation
- All parts of buildings requiring fire retardant materials

### Specification Overview

#### High tensile 'bounce back' aluminium slat:

- 25mm Premium - 0.215mm thick
- 50mm Classic - 0.200mm thick

Head and bottom rail manufactured from zincalume steel that has been stove-enamelled for excellent corrosion resistance.

### Durability

Manually operated products have been cycle tested to ensure longevity.

### Energy Benefits

Aluminium Venetians are effective reflectors of heat, particularly in light and metallic colours.

Automated Venetian Blinds can be connected to building management systems for optimal control of air conditioning loads and comfort of the building occupants.

### Environmental and Employee Benefits

The adjustable light control function of Venetian Blinds means that the use of natural light in the workplace can be maximised, which is important for individual productivity and well being while reducing the need for artificial lighting. Perforated Venetian Blinds provide shading while allowing the building occupants a view to the outside, reducing the feeling of disconnection from the outside world.

The slats in Aluminium Venetian Blinds are made from up to 99% recycled materials.

New Zealand Window Shades operates under an Environmental Management System that actively works towards waste and emission reduction and maximising the use of recycling.

### Quality

Hunter Douglas Limited, the supplier of the Aluminium Venetian Blind components, is a quality endorsed company, certified as complying with the requirements of AS/NZS ISO 9001:2000.

### Commercial Warranty

All Aluminium Venetian Blinds are covered by a one year Commercial Warranty. Conditions apply.



# ALUMINIUM VENETIAN BLINDS

## CONSTRUCTION



### Headrail

The headrail is U-shaped zincalume steel roll-formed and stove-enamelled, incorporating the tilt/raise and lowering mechanism.

### Tiltstop and Clutch

A tiltstop and clutch is fitted to limit tilt-rod rotation at the blind's fully closed position to prevent damage to the tilting mechanism from overwinding (25mm Gold Star models).

### Slats

Premium Gold Star slats are made from a 0.215mm thick high tensile aluminium alloy, (selected special finish colours and 50mm slats are made from 0.200mm thick material), which is pre-treated prior to painting for corrosion resistance and is crowned to improve its rigidity and strength. The slats are stove-enamelled, making them resistant to abrasion, peeling, scratching, dulling, discolouration and corrosion.

### Thermostop® Slats

The thermostop® Slat is based on a slat which has a special coating on the concave side of the slat, giving an emission of heat radiation three times lower (Emission value 30% instead of 90% for a normal painted slat). This special finish increases the thermal resistance in winter and decreases the inside heat transfer in summer.

### Bottom Rail

The bottom rail is made from D shaped steel for maximum rigidity, is stove-enamelled and fitted with colour co-ordinated end caps.

### Automated Tilt and Raise and Auto-tilt

This option provides the ultimate in technology and operating comfort. The angle of the slats are adjusted to suit your requirements by a simple remote control. The blind is operated by a built in electric motor. There is a choice of switches, group operation, infrared remote, radio remote or solar control. 25mm blinds are operated by 24V motors and 50mm blinds are operated by 240V motors. Auto Tilt option allows you to adjust the operation of the slat only with a battery operated motor and remote. (25mm only)

### Colour Co-ordination

For premium Gold Star slat all visible components are colour co-ordinated to the colour of the slats (with the exception of the wand).



# ALUMINIUM VENETIAN BLINDS

## MODELS & OPTIONS



### 25mm Premium Gold Star SLIMLINE® Venetian Blinds

For the discerning buyer who wants only the best, Gold Star Grade Venetians fit this criteria. These blinds feature heavy duty slat, full colour co-ordination from headrail to bottom rail and a choice of over 60 fashion colours.

The wand incorporates an overriding clutch mechanism. Slat overlap is 5mm.

Spring loaded hold down clips available to hold bottom rail in fixed position.



### 25mm TWI-NIGHTER® Venetian Blinds: the Venetian Blind without visible holes

A Twi-Nighter® Venetian Blind has no visible holes, which means no reflections on the computer screen. For this reason Twi-Nighter Venetian Blinds are suitable for windows in direct sunlight. Also ideal for optimal security and privacy (e.g. separation walls). Available as 25mm only. Automation is not available. Slat overlap 7mm.

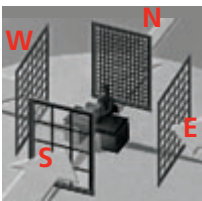

### Perforations

Various perforation options are available. This innovative solution allows you to choose the shade solution suitable for different facade orientations (8% on south facade, 4% on east, north and west facade). These perforation options provide the ideal solution for optimal daylight regulation.



### 25mm In Between Glass Venetian Blinds

For hanging between panes operation is available through manual tilt or Automated. Manual tilting is by way of rotation knob.

NOTE: 40mm between panes required for installation.

### 50mm Classic Venetian Blinds

For Retro styling, the 50mm is truly a Classic in Venetian Blind design. Utilising a 50mm headrail system, and 50mm wide high tensile aluminium alloy slats, the Classic is a great choice for schools, offices or residential.

The 50mm is available in a range of plain and perforated colours with string tape as standard and 12mm tape available on selected colours for increased privacy.

Concealed face or reveal fitting spring loaded brackets, along with a headrail end cap and colour co-ordinating headbox and bottom rail, provide a stylish, clean line appearance. Slat overlap is 9mm.

### 25mm Venetian Blinds - Speciality Shapes

Venetian Blinds are available in a variety of special shapes to suit modern glazing. Maximum slope 45°. Top sloper will raise to start of slope and bottom sloper is static and tilt only.

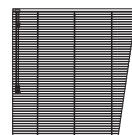
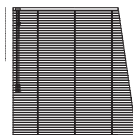
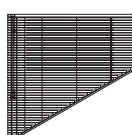
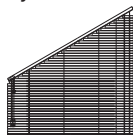

### Automated-electric Tilt and Raising

The blind is powered by a built-in electric motor. There is a choice of separate switches, group operation, infra-red remote, radio remote. 25mm blinds are operated by 24V motors, and 50mm blinds by 240V motors. Battery powered tilt-only operation is also available in 25mm. For further information on Automation refer to the Automation section of this manual.



# ALUMINIUM VENETIAN BLINDS

## SPECIFICATION & SIZE LIMITATIONS

### Dimensions

Type	25mm Slimline	25mm TWI-NIGHTER®	50mm Classic
Minimum Width	210mm	210mm	300mm
Maximum Width	3300mm	3300mm	3600mm
Maximum Drop	3200mm	3200mm	3200mm
Maximum Area	9m <sup>2</sup>	9m <sup>2</sup>	12m <sup>2</sup>
Stack Height	(.034 x drop +45 mm)	(.036 x drop +45mm)	(.05 x drop +45mm)
Split Control	400mm & under	400mm & under	450mm & under

### Installation

If required, sill clips may be fitted.

#### Face Fit

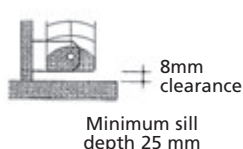

#### Reveal Fit



If required, spring loaded hold down catches may be fitted.

#### Recessed head detail

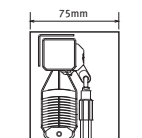
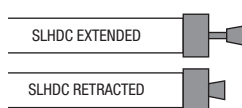

### In-Between Glass

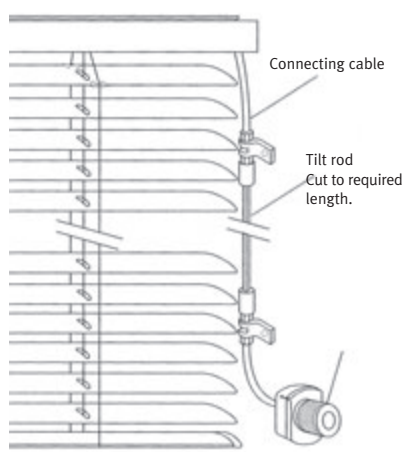

(40mm between panes required for installation)

### Standard Product Dimensions

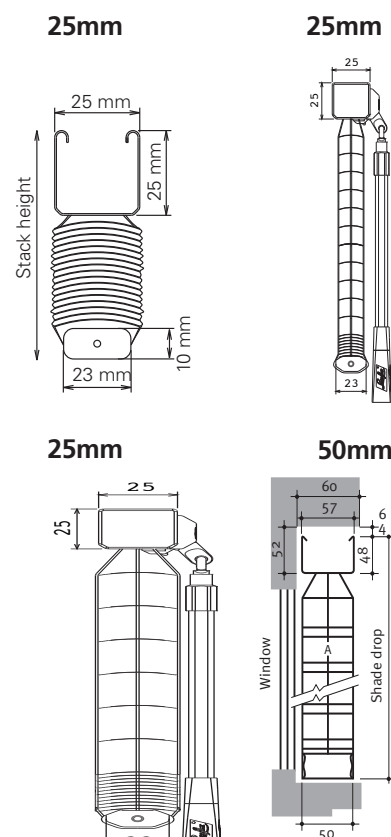

### Specification Templates

Product Name	Aluminium Venetian Blinds - 25mm.
Model	25mm Slimline/25mm TWI-NIGHTER®/In Between Glass
Slat Material (Premium Gauge)	The slats shall be manufactured from 0.215mm thick high tensile aluminium alloy which are crowned. The crowned slat shall be flexible enough to bend 180° around a 12.5mm radius without incurring any permanent deformation.
Slat Dimensions	25mm TWI-NIGHTER: the slat width is 25mm with a 7mm slat overlap 25mm Slimline: the slat width is 25mm with a 5mm slat overlap
Polyester Cord	The core of the polyester cord shall be 1.5mm thick with a braided jacket.
Head & Bottom Rails	Fabricated from 0.5mm hot-dipped aluminium zinc coated steel. The finish is 12 ±2 microns thick and comprises a thermoset polymer coating over primer.
Colour & finish	The colour shall be co-ordinated with trims.
Control	The blind shall be operated by wand/Automated/control knob (in-between glass model)
Automation Type	It shall incorporate automatic down stop/automatic up stop/low speed tilting/remote control/switch control.
Clutch	Wand operated 25mm Aluminium Venetian Blinds shall contain the clutch mechanism.

Product Name	50mm Classic Aluminium Venetian Blinds.
Slat Material	The slats shall be manufactured from 0.200mm thick high tensile aluminium alloy 6001 T8. The crowned slat shall be flexible enough to bend 180° around a 12.5mm radius without incurring any permanent deformation.
Slat Dimensions	The slat width is 50mm with a 9mm slat overlap.
Polyester Cord	The core of the polyester cord shall be 2.3mm thick with a braided jacket.
Headrails	The 98 MK2 Headrail Is manufactured from .04 steel alloy 930052.AZ150.
Bottom Rail	The VB50 Bottom Rail is a 2 piece Bottom Rail manufactured from .60 aluminium alloy 5005 H16NAT
Colour	The colour shall be .... plain/perforated with 12mm tape/string tape and coordinated trims.
Automation Type	It shall incorporate automatic down stop/automatic up stop/low speed tilting/remote control/switch control.

# ALUMINIUM VENETIAN BLINDS

## SPECIFICATION & SIZE LIMITATIONS

### Dimensions

Type	25mm Slimline	25mm TWI-NIGHTER®	50mm Classic
Minimum Width	210mm	210mm	300mm
Maximum Width	3300mm	3300mm	3600mm
Maximum Drop	3200mm	3200mm	3200mm
Maximum Area	9m <sup>2</sup>	9m <sup>2</sup>	12m <sup>2</sup>
Stack Height	(.034 x drop +45 mm)	(.036 x drop +45mm)	(.05 x drop +45mm)
Split Control	400mm & under	400mm & under	450mm & under

### Installation

If required, sill clips may be fitted.

#### Face Fit

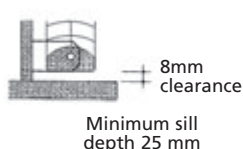

#### Reveal Fit



If required, spring loaded hold down catches may be fitted.

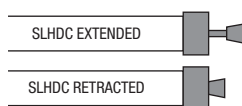

#### Recessed head detail

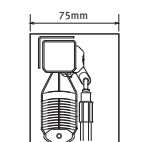

### In-Between Glass

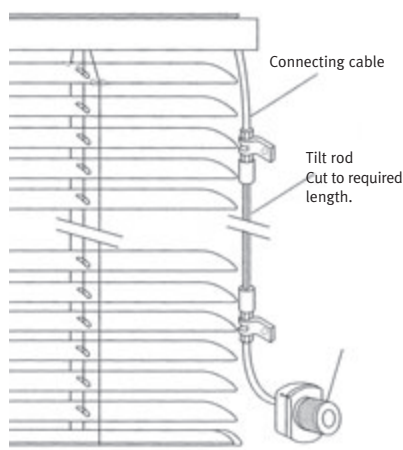

(40mm between panes required for installation)

### Standard Product Dimensions

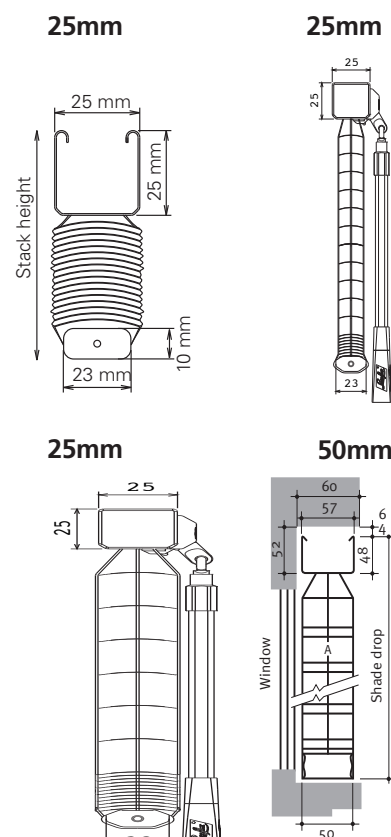

### Specification Templates





Product Name	Aluminium Venetian Blinds - 25mm.
Model	25mm Slimline/25mm TWI-NIGHTER®/In Between Glass
Slat Material (Premium Gauge)	The slats shall be manufactured from 0.215mm thick high tensile aluminium alloy which are crowned. The crowned slat shall be flexible enough to bend 180° around a 12.5mm radius without incurring any permanent deformation.
Slat Dimensions	25mm TWI-NIGHTER: the slat width is 25mm with a 7mm slat overlap 25mm Slimline: the slat width is 25mm with a 5mm slat overlap
Polyester Cord	The core of the polyester cord shall be 1.5mm thick with a braided jacket.
Head & Bottom Rails	Fabricated from 0.5mm hot-dipped aluminium zinc coated steel. The finish is 12 ±2 microns thick and comprises a thermoset polymer coating over primer.
Colour & finish	The colour shall be co-ordinated with trims.
Control	The blind shall be operated by wand/Automated/control knob (in-between glass model)
Automation Type	It shall incorporate automatic down stop/automatic up stop/low speed tilting/remote control/switch control.
Clutch	Wand operated 25mm Aluminium Venetian Blinds shall contain the clutch mechanism.

Product Name	50mm Classic Aluminium Venetian Blinds.
Slat Material	The slats shall be manufactured from 0.200mm thick high tensile aluminium alloy 6001 T8. The crowned slat shall be flexible enough to bend 180° around a 12.5mm radius without incurring any permanent deformation.
Slat Dimensions	The slat width is 50mm with a 9mm slat overlap.
Polyester Cord	The core of the polyester cord shall be 2.3mm thick with a braided jacket.
Headrails	The 98 MK2 Headrail Is manufactured from .04 steel alloy 930052.AZ150.
Bottom Rail	The VB50 Bottom Rail is a 2 piece Bottom Rail manufactured from .60 aluminium alloy 5005 H16NAT
Colour	The colour shall be .... plain/perforated with 12mm tape/string tape and coordinated trims.
Automation Type	It shall incorporate automatic down stop/automatic up stop/low speed tilting/remote control/switch control.

# ALUMINIUM VENETIAN BLINDS

## COMFORT RATING

25mm Slimline, TWI-NIGHTER and 50mm Classic

COLOUR					
Black	◆◆◆	◆	◆◆◆◆	blockout	◆◆◆◆
Bright Silver	◆◆◆◆◆	◆	◆◆◆◆	blockout	◆◆◆◆
Clean Brilliant White	◆◆◆◆◆	◆	◆◆◆◆	blockout	◆◆◆◆
Crisp Cotton	◆◆◆◆◆	◆	◆◆◆◆	blockout	◆◆◆◆
Glazed Fawn	◆◆◆◆	◆	◆◆◆◆	blockout	◆◆◆◆
Grey Sheen	◆◆◆◆	◆	◆◆◆◆	blockout	◆◆◆◆
Euro Rich Cream	◆◆◆◆◆	◆	◆◆◆◆	blockout	◆◆◆◆
Shale	◆◆◆	◆	◆◆◆◆	blockout	◆◆◆◆
Shimmer Gold	◆◆◆◆◆	◆	◆◆◆◆	blockout	◆◆◆◆
Sterling	◆◆◆◆	◆	◆◆◆◆	blockout	◆◆◆◆
Chocolate	◆◆◆	◆	◆◆◆◆	blockout	◆◆◆◆
Traditional Donkey	◆◆◆◆◆	◆	◆◆◆◆	blockout	◆◆◆◆
Ebony	◆◆◆	◆	◆◆◆◆	blockout	◆◆◆◆
Grape	◆◆◆◆	◆	◆◆◆◆	blockout	◆◆◆◆
Grey Gloss	◆◆◆◆◆	◆	◆◆◆◆	blockout	◆◆◆◆
Latin Gulf Blue	◆◆◆◆	◆	◆◆◆◆	blockout	◆◆◆◆
Indigo Ash	◆◆◆	◆	◆◆◆◆	blockout	◆◆◆◆
Ancient Jade	◆◆◆◆	◆	◆◆◆◆	blockout	◆◆◆◆
Latte	◆◆◆◆	◆	◆◆◆◆	blockout	◆◆◆◆
Linen	◆◆◆◆◆	◆	◆◆◆◆	blockout	◆◆◆◆
Mocha	◆◆◆	◆	◆◆◆◆	blockout	◆◆◆◆
Steel Nordic Blue	◆◆◆◆	◆	◆◆◆◆	blockout	◆◆◆◆
US Paperbank	◆◆◆◆◆	◆	◆◆◆◆	blockout	◆◆◆◆
Warm Pure Silk	◆◆◆◆◆	◆	◆◆◆◆	blockout	◆◆◆◆
Jet Red Currant	◆◆◆◆	◆	◆◆◆◆	blockout	◆◆◆◆
Pale Sky	◆◆◆◆◆	◆	◆◆◆◆	blockout	◆◆◆◆
Storm	◆◆◆	◆	◆◆◆◆	blockout	◆◆◆◆
Deep Stratford Blue	◆◆◆	◆	◆◆◆◆	blockout	◆◆◆◆



**Fire Retardant**  
[AS 1530.3.1999]

Complies with the General and Special Requirements of the Building Code of Australia for Fire Hazard properties of materials in buildings, as at the time of publication of this document.





Ignitability Index 0 [Range 0-20] Spread of Flame Index 0 [Range 0-10]  
Heat Evolved Index 0 [Range 0-10] Smoke Developed Index 0-1 [Range 0-10]

### Solar Optical Properties:

As - Heat Absorbance (%)      Rs - Heat Reflectance (%)  
Ts - Heat Transmittance (%)      AL - Light Absorbance (%)  
RL - Light Reflectance (%)      TL - Light Transmittance (%)  
SC - Shading Coefficient      R1 - R-Value single glazing  
R2 - R-Value double glazing

### COMFORT RATING™

- ◆◆◆◆ Highest level of protection/performance
- ◆◆◆ High level of protection/performance
- ◆◆ Medium level of protection/performance
- ◆◆ Low level of protection/performance
- ◆ No protection

-  Heat Protection
-  Insulation
-  Shade Factor
-  Glare Reduction
-  UV Protection

# ALUMINIUM VENETIAN BLINDS

## SPECIFICATION SHEET

### 25mm Slimline, TWI-NIGHTER and 50mm Classic

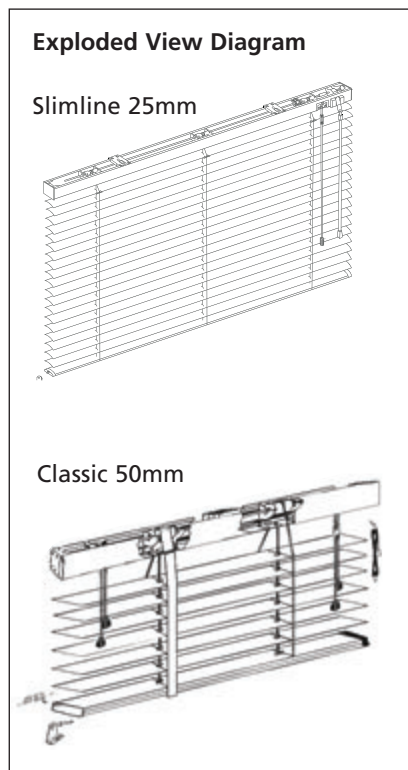

#### Limitations

Aluminium Venetian Blind limitations have been developed to ensure the blind operates and performs to maximum potential.

Measurements outside of these parameters may not perform to our Quality Standards and will be void of warranty.

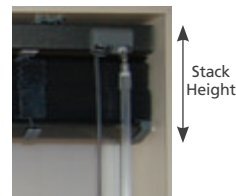

	Minimum Width	Maximum Width	Minimum Height	Maximum Height	Stack Height
25mm	210mm	3300mm	250mm	3200mm	(Drop x 0.34)+0.45
50mm	300mm	4000mm	180mm	3500mm	(Drop x 0.50)+0.45
Two-Nighter	210mm	3300mm	250mm	3200mm	(Drop x 0.34)+0.45

#### Slat Composition

6011 Aluminium Alloy. High tensile bounce back. (Gold Star Range)

#### Width

25mm & 50mm

#### Headbox

The 25mm Aluminium Venetian Blind uses a 26mm wide x 26mm deep strip rolled from pre-coated 0.5mm aluminium zinc alloy coated steel finished in a Thermosetting Polyester Coating over a chromated primer, adding strength and rigidity to the headrail.

#### Bottomrail

The 25mm Aluminium Venetian Blind uses a D-shaped 22.5mm x 10mm lock seamed tubular section, roll formed from 0.5mm aluminium zinc alloy coated steel, finished in a Thermosetting Polyester Coating over a chromated primer. This fully enclosed bottom rail adds weight and maximum strength for rigidity. The coating process meets Coil Coating

#### Standards

(AS/NZS2728:2007) to ensure paint adhesion flexibility and resistance to solvents and has been stove enamelled for greater corrosion resistance.

#### Stringtape

Woven to strict specification which allows you more slat overlap for light control.